



沧州盛世伟业汽车配件有限公司

CANGZHOU SHENGSHIWEIYE AUTOMOBILE ACCESSORY CO.,LTD



SHENGSHIWEIYE

CANGZHOU SHENGSHIWEIYE AUTOMOBILE ACCESSORY CO.,LTD

Kongzhuang, Guozhuang Town, Xian County, Cangzhou City,
Hebei China. Tel:86-317-2049866

Fax:86-317-2049688

Mobile phone:8618713779288

Email: wheelweight9@ssqcpj.com



AUTO TIRE VALVES

Focusing on the development, production and sales of automotive repair tools

Brief introduction of enterprise

企业简介

沧州盛世伟业汽车配件有限公司，位于美丽的渤海之滨，历史名城河北沧州。公司成立于2006年11月，前身是始建于1996年的沧州汽车附件厂，是一家专业生产汽车维修检测设备、工具和轮胎耗材的制造厂商。拥有员工近百人，占地面积20000余平方米，建筑面积近万平方米，拥有固定资产上千万。

公司专业生产：汽车平衡块、气门嘴、胶条、胶片、润滑油等轮胎耗材产品以及汽车平衡机、拆胎机、四轮定位仪、举升机、补胎机、各类轮胎拆装设备和维修工具。

公司创建伊始就秉承着敬业务实，创新卓越的经营理念，立足于技术革新，研究国内外市场发展趋势，产品定位先进实用，重视产品生产检测工艺水平，积极开发让客户更满意的产品投放市场。

自1996年开始大力服务于汽车售后市场，公司与国内乃至世界各国客户达成了良好合作，先后为金龙客车、中国一汽、北汽福田、北京现代、长安福特、保定长城、陕汽重卡、上汽集团、Tiptop、俄罗斯Rossvik、俄罗斯卡玛斯、泰国马自达、铃木、巴基斯坦丰田、本田、五十铃等国际国内一流汽车制造厂提供产品配套解决方案。

同时，盛世伟业始终重视并不断提升产品的工艺水平，先后通过了ISO9001-2000和TS16949产品质量管理体系认证，德国莱茵CE、法国BV、英国LNTERTEK和UKCA以及沙特的SASO等诸多国际标准认证。

公司先后取得了国内商标注册两项、国际商标6项、其中美国一项、欧洲三项、俄罗斯一项、中东市场一项，先后取得发明制造和实用新型以及外观专利二十余项，盛世伟业的产品在北美、南美、欧洲、东南亚、非洲和中东等国内外市场受到诸多客户的喜爱与青睐。

盛世人始终坚持“质量第一，客户至上”的原则，坚定的与新老客户一起携手共建共赢！

Cangzhou Shengshiweiye Automobile Accessory Co., Ltd. is located in the beautiful historical city of Cangzhou, Hebei, on the coast of the Bohai Sea.

The company specializes in the production of wheel balance weight, tire valve, tire seal string, tire patch, tire mounting paste and other tire consumables, and wheel balancer, tire changer, wheel alignment, car lift, tire repair machines, various tire disassembly equipment and repair tools.

The company specializes in the production of wheel balancer, tire changer, wheel alignment, car lift, tire repair machines, various tire disassembly and repair tools, wheel balance weight, tire valve, tire seal string, tire patch, tire mounting paste and other tire consumables.

At the beginning of its establishment, the company adhered to the core concept of dedication, pragmatism, and innovation excellence. Based on technological innovation, it studied the development trends of domestic and foreign markets, positioned its products as advanced and practical, valued the level of product production and testing technology, and actively developed products that would satisfy customers and put them on the market.

Since 1996, the company has been vigorously serving the automotive after-sales market and has established good cooperation with customers from both domestic and international markets. It has successively provided services to King Long, FAW China, BAIC Foton, Beijing Hyundai, Changan Ford, Baoding Great Wall, Shanxi Automobile Heavy Truck, SAIC Group, Tiptop, Russia Rossvik, Russia Camus, Thailand Mazda, Suzuki, Pakistan Toyota, Honda, Isuzu and other international and domestic first-class car maker manufacturers to provide product supporting solutions.

At the same time, Shengshiweiye has always attached great importance to and continuously improved the technological level of its products. It has successively passed ISO9001-2000 and TS16949 product quality management system certifications, Rheinland CE, BV, LNTERTEK and UKCA, and SASO and many other international standards certifications.

The company has obtained two domestic trademark registrations and six international trademarks, including one in the United States, three in Europe, one in Russia, and one in the Middle East market. It has obtained more than 20 patents for invention, manufacturing, utility models, and appearance. Shengshiweiye's products are in North America, South America, Europe, and Southeast Asia, Domestic and foreign markets such as Africa and the Middle East are loved and favored by many customers.

Shengshi people will be always adhering to the principle of "quality first, customer first", and firmly working with new and old customers with a win-win situation!

Zn	ZINC	ALUMINUM RIM	PASSENGER CAR	COATED
Pb	LEAD	STEEL RIM	MOTORCYCLE	OEM PRODUCT
Fe	STEEL		LIGHT TRUCK	
PP	POLY		TRUCK	

资质证书 INTELLIGENCE NORTHPLPEAPER



Snap-in Tubeless Rubber Valves



TR NO.	ETRTO NO.(REF.NO.)	RIM HOLE	EFF. LENGTH (mm)	A	B	C
Tr412	V2.03.6	11.5(.453" dia)	22	33	22	15
Tr413	V2.03.1	11.5(.453" dia)	32	42	32	15
Tr414	V2.03.2	11.5(.453" dia)	38	48	38	15
Tr415	V2.03.3	16(.625" dia)	32	42	32	15
Tr418	V2.03.4	11.5(.453" dia)	51	62	51	15
Tr438	V2.03.5	8.8(.346" dia)	31	40.5	31	11
Tr425		16(.625" dia)	51	62	51	19.2
Tr414L	V2.03.8	11.5(.453" dia)	46	56.5	46	15
Tr423		11.5(.453" dia)	63	74	63	19.2



Tr413C-Y Tr413C-P Tr413C-R Tr413C-B Tr413C-G Tr413C Tr414C
Tr413C-G Tr413C-B Tr413C-Y Tr413C-P Tr413C-R Tr413AC Tr414AC

Tubeless Metal clamp-in Valves



TR NO.	EFF. LENGTH (mm)	RIM HOLE(mm/in.)	ETRTO NO.(REFNO.)
MS525S	Φ17.5x41.5	Φ11.5/1.453"	-
MS525L	Φ17.5x41.5	Φ11.5/1.453"	-
MS525AL	Φ17.5x42	Φ11.5/1.453"	-
VS-8-45°	Φ16x53-459	Φ11.5/1.453"	WH303 PVR75A
VS-8-90°	Φ16x63-90	Φ11.5/1.453"	-
PVR153	Φ17xL-90°	Φ11.5/1.453"	-



TR NO.	EFELENGTH(mm)	RIM HOLE(mm/in.)	GROMMET	WASHER	NUT
Tr416	Φ18.5x40	Φ16/1.625"	RG39	RW13	HN4
Tr416S	Φ17x40	Φ11.5/.453"	RG54	RW8	HN4
Tr26A	Φ16x34	Φ11.5/.453"	HRG1,HG2	RW12	HN2x2
Tr33E	Φ14x33	Φ11.5/.453"	HRG2x2	RW5	HN2x2
Tr43E	Φ14x43	Φ11.5/.453"	HRG2x2	RW5	HN2x2
Tr48E	Φ14x48	Φ11.5/.453"	HRG2x2	RW5	HN2x2
Tr53E	Φ14x53	Φ11.5/.453"	HRG2x2	RW5	HN2x2
Tr26G	Φ16x38	Φ11.5/.453"	HRG1,HG2	RW12	HN2x2
Tr435	Φ19x34	Φ11.5/.453"	RG54	RW8	HN4

Tubeless etel clamp-in Valves For Truck And Bus



FOR $\Phi 16(.625"$ dia.) RIM HOLES

TR NO.	EFF. LENGTH (mm)	CORE	GROMMET	WASHER	NUT	CAP
Tr575	$\Phi 19 \times 33$	9002#	RG15	RW8	HN13	DT
Tr501	$\Phi 19 \times 42$	9002#	RG15	RW8	HN13	DT
Tr500	$\Phi 19 \times 55$	9002#	RG15	RW8	HN13	DT
Tr500-35°	$\Phi 19 \times 55 / 35^\circ$	9002#	RG15	RW8	HN13	DT
Tr572C-27°	$\Phi 19 \times 100$	9002#	RG15	RW8	HN13	DT
Tr572C-90°	$\Phi 19 \times 100$	9002#	RG15	RW8	HN13	DT
Tr570P	$\Phi 12 \times 18$	9002#	RG7	RG11	HN1	DT
Tr570	$\Phi 19 \times 84$	9002#	RG15	RW8	HN13	DT
Tr571	$\Phi 19 \times 90$	9002#	RG15	RW8	HN13	DT
Tr572	$\Phi 19 \times 100$	9002#	RG15	RW8	HN13	DT
Tr573	$\Phi 19 \times 115$	9002#	RG15	RW8	HN13	DT
Tr574	$\Phi 19 \times 131$	9002#	RG15	RW8	HN13	DT

Tubeless Metal clamp-in Valves

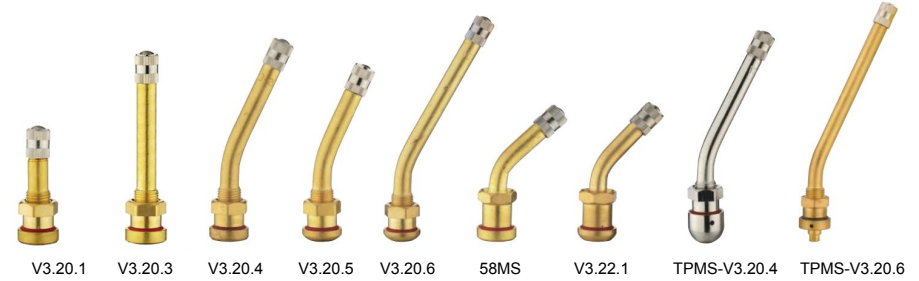

TR NO.	EFF. LENGTH (mm)	CORE	GROMMET	NUT
V3.20.1	$\Phi 16 \times 41$	9002#	V9.11.5 (RG60)	V9.07.2
V3.20.3	$\Phi 16 \times 82$	9002#	V9.11.5 (RG60)	V9.07.2
V3.20.4	$\Phi 16 \times 90$	9002#	V9.11.5 (RG60)	V9.07.2
V3.20.5	$\Phi 16 \times 70$	9002#	V9.11.5 (RG60)	V9.07.2
V3.20.6	$\Phi 16 \times 80 /$	9002#	V9.11.5 (RG60)	V9.07.2
58MS	$\Phi 16 \times 58 / 45^\circ$	9002#	V9.11.5 (RG60)	V9.07.2
TPMSV3.20.4	$\Phi 16 \times 90 / 27^\circ$	9002#	V9.11.5 (RG60)	V9.07.2
TPMSV3.20.6	$\Phi 16 \times 80 / 27^\circ$	9002#	V9.11.5 (RG60)	V9.07.2

Air-Liquid Valves For Agricultural Tractors



TR NO.	EFF. LENGTH (mm)	CORE	GROMMET	NUT
Tr618	$\Phi 22.5 \times 56$	9002#	-	-
Tr618A	$\Phi 22.5 \times 30$	9002#	RG7	HN1
Tr623A	A42.5 B36 $\alpha 65^\circ$	TR CH3	RW31	HN3
Tr621A	A42.5 B55 $\alpha 65^\circ$	TR CH3	RW32	HN3
Tr622A	A47.5 B94 $\alpha 90^\circ$	TR CH3	RW31	HN3

Larde Bore Swivel Tupe Valves



TR NO.	A	B	α°
TRJ650-03	27	79	80
TRJ651-03	32	119	90
TRJ652-03	27	140	86
TRJ653-03	27	64	80
TRJ654-03	27	79	60
TRJ655-03	24	79	74
TRJ656-03	67	94	90
TRJ657-03	27	102	80
TRJ658-03	27	140	80
TRJ659-03	48	89	90
TRJ660-03	48	222	90
TRJ669-03	27	64	90
TR670-03	41	-	-

European Stule clamp-in Valves

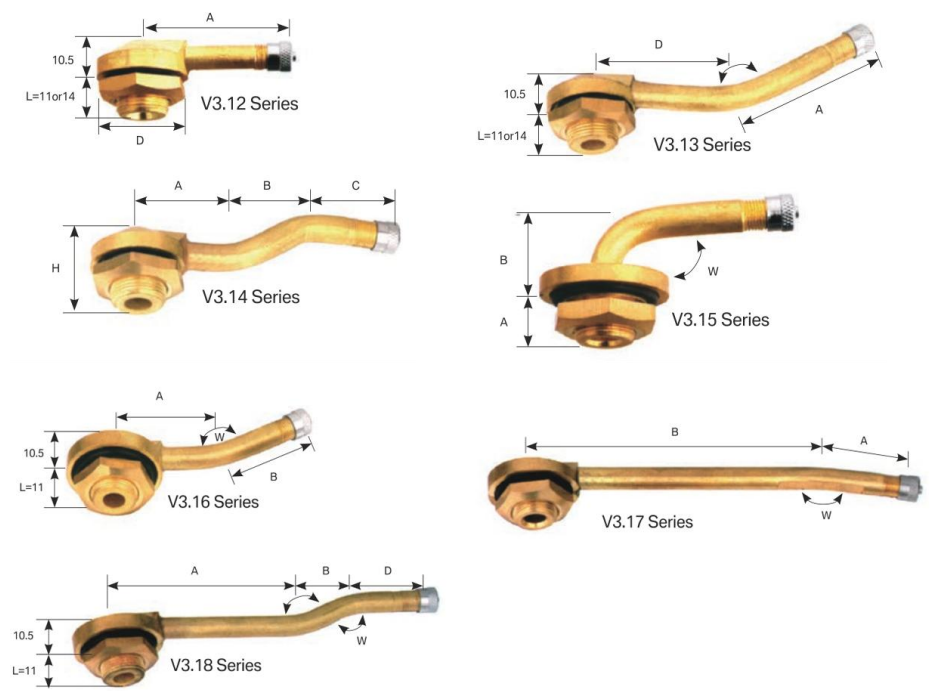

TR NO.	A	B	C-	D	W°	H
V3.12.1	40	-	-	-	-	-
V3.12.2	95	-	-	-	-	-
V3.13.1	42.5	-	-	46.5	153	-
V3.13.2	79	-	-	30	126	-
V3.14.1	25	21.5	24.5	-	-	21
V3.14.2	45	21.5	24.5	-	-	21
V3.14.3	37	21.5	24.5	-	-	21
V3.15.1	14	22.5	-	-	110	-
V3.15.2	11	15.5	-	-	95	-
V3.16.1	36	29	-	-	150	-
V3.17.1	99	31.5	-	-	172	-
V3.17.2	116	31.5	-	-	172	-
V3.18.1	64	24.5	-	14.5	146	-
V3.18.2	81	24.5	-	14.5	146	-
V3.18.4	51	37.5	-	19.5	138	-
V3.18.5	68	-37.5	-	19.5	138	-

TPMS Valves



MS525AL
Round Base

MS525AL
Flat Base



TR NO.	EFFLENGTH(mm)	RIM HOLE(mm/In.)	GROMMET	WASHER	NUT
MS525AL-Round Base	Φ18x48	Φ11.51.453"	RG54	HN9	ET
MS525AL-Flat Base	Φ18x42	Φ11.51.453"	RG54	HN9	ET



TPMS-01

Adapted models:Alpha, Romeo, Albina, Aston Martin, Audi, BMW, Bentley, Bugatti, Ferrari, Lamborghini, Land Rover, Maserati, Maybach, McLaren, Mercedes Benz, Mini, Pagani, Porsche, Rolls Royce, Skoda, Ssanglong, Tesla, Volkswagen Kia, Hyunda



TPMS-03

New Land Rover, Volvo, Hyundai/Sonata, Shengda/Dodge, Kia K5, BMW



TPMS-05

Baba Silk, Buick, Cadillac, Chevrolet, Chrysler, Dodge, Fiat, Hummer, GMC, Modern, Jeep, Mazda



TPMS-07

Modern, Kia



TPMS-09

Abbas, Buick, Cadillac, Chevrolet, Citroen, Expiration, Fiat, Ford, Hummer, Hyundai, GMC, Jeep, Mazda, Masindra, Opel



TPMS-02

Adapted models:Alpha, Romeo, Albina, Aston Martin, Audi, BMW, Bentley, Bugatti, Ferrari, Lamborghini, Land Rover, Maserati, Maybach, McLaren, Mercedes Benz, Mini, Pagani, Porsche, Rolls Royce, Skoda, Ssanglong, Tesla, Volkswagen Kia, Hyunda



TPMS-04

Iron General, Nissan, Qijun, BMW X5, Mitsubishi, JEBP, Market installation



TPMS-06

Feiler



TPMS-08

Old Land Rover, Volkswagen, Dodge, Rams, Hyundai, Jeep, Fiat, Chrysler, Jaguar, Jaguar, Citroen, logos



TPMS-10

Nissan, Touareg

Motorcycle vacuum valve



Tr218A

TR NO.	A	D	CORE HOUSING	CAP
TR218A	27	63.5182	TRCH3	VC618

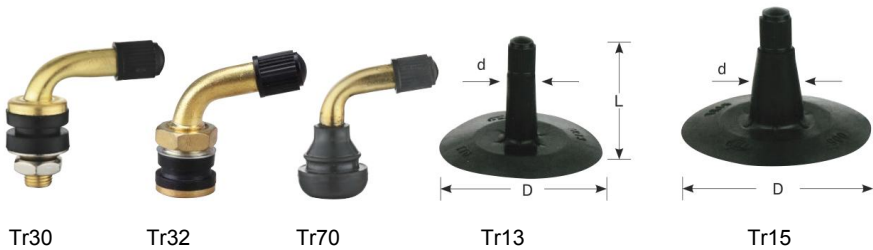

Tr30

Tr32

Tr70

Tr13

Tr15

TR NO.	REF. LENGTH(mm)	RIM HOLE(mm/In.)	CAP
Tr30	Φ15x63x90°	Φ11.51.453"	VC8
Tr32	Φ16x54x90°	Φ11.51.453"	VC8
Tr70	Φ20x32x90°	Φ11.51.453"	VC8

TR NO.	L	D	d
Tr13	38	56	11.5
Tr15	38	56	16.5

Tire Valve Cores



9001

9002

9003

9004

Short valve core with inside spring. applied to tire valve with No. 1 core chamber(5V1).

Thead	Washer Material	Gasket Material	Working Temp. Range	Working Pressure Range	Installation Torque
5V1	Teflon	SR	-40°C ~+120°C	0~1.5MPa	0.23N.m~0.34N.m



8001

8002

8003

8004

Long valve core with outside spring. applied to tire valve with No. 1A core chamber(5V1).

Thead	Washer Material	Gasket Material	Working Temp. Range	Working Pressure Range	Installation Torque
5V1	Teflon	SR	-40°C ~+120°C	0~1.5MPa	0.23N.m~0.34N.m

Extension tube single clip



Metal bending inflatable

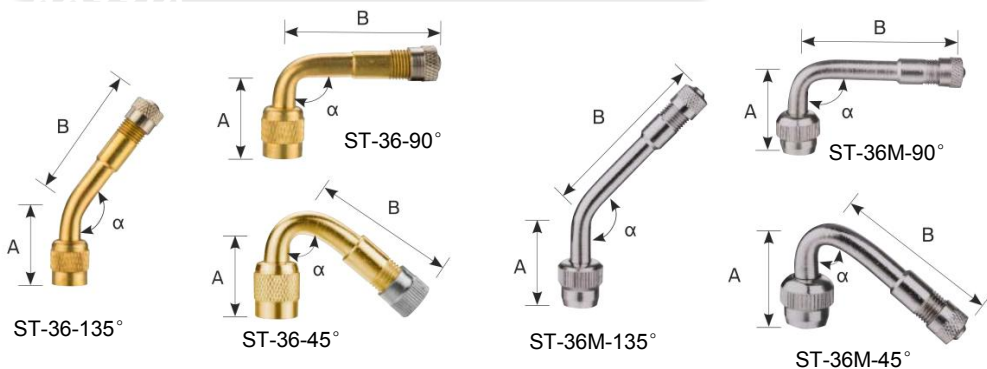

TR NO.	A (mm)	B (mm)	α
ST-36-45°	24.5	34	45°
ST-36-90°	24.5	34	90°
ST-36-135°	24.5	34	135°
ST-36M-45°	25	34	45°
ST-36M-90°	25	34	90°
ST-36M-135°	25	34	135°

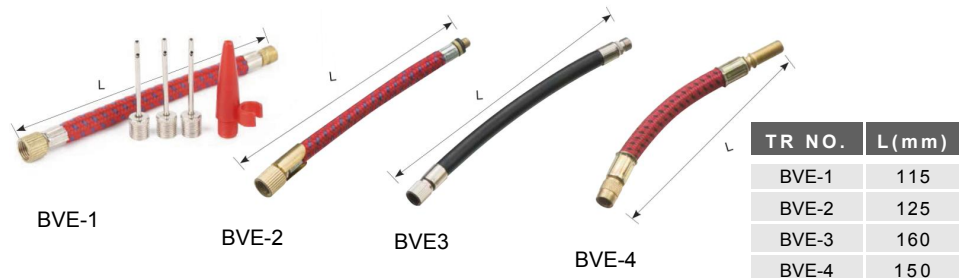

TR NO.	L (mm)
BVE-1	115
BVE-2	125
BVE-3	160
BVE-4	150

Valve inflation extension



TR NO.	DESCRIPTION	LENGTH (mm)	ϕ (mm)
ST-125RM	Extension	125	12/10
ST-180RM		180	12/10
ST-250RM		250	12/10
ST-250RM-FVE1		250	12/10
ST-MU	EXTENSION WITH U-SHAPE CLIP	210	12/10
ST-BEF		250	12/10



TR NO.	LENGTH (mm)	ϕ (mm)
ST-120R-FVE1	210	12/10
ST-125R	125	12/10
ST-180R	180	12/10
ST-562	360	12

S-T001



Tire Valve Core Screw

S-T002



Valve Puller

S-T003



Air Chuck

S-T004



S-T012



Tire Lubricating Paste

S-T013



Brush

S-T014



Ball Bearing Stitcher

S-T015



Wheel Weight Plier

S-T005



Air Chuck

S-T006



Tire Pressure Gauge

Tire Tread Measuring Tool

S-T016



Cross Wrench

S-T017



Cross Wrench

S-T018



Grinder Head

S-T019



Grinder Head Tool Set

S-T007



Quick Connector

S-T020

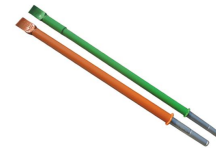

Tire Changing Tools

S-T021



Tyre Layering Extractor

S-T022



Tire Lever

S-T023



Motorcycle Wheel Bracket

S-T008



Shockproof Tire Inflating Gauge

S-T009



Pointer Type Tire Inflating Gauge

S-T010



Tire Inflating Gauge

S-T011



Digital Tire Inflating Gauge

S-T024



Plastic Wheel Chock

S-T025



Wheel Chock Holder

S-T026



Steel Car Ramp

S-T027



Plastic Car Ramp